

ASC-600-SLMC

Electromatic Locks w/ Contacts

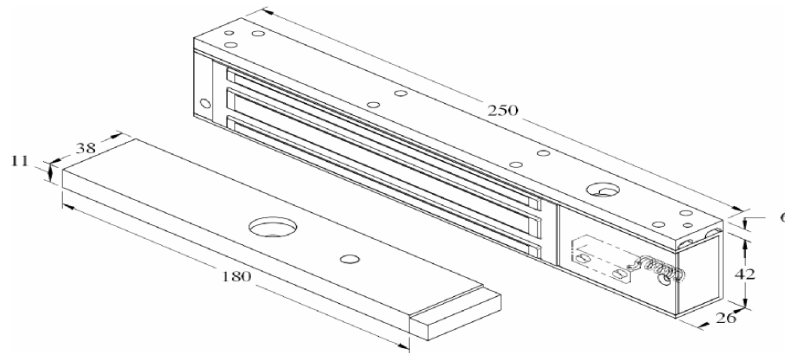

FEATURES :

- * Holding force : Up to 600lbs
- * Door Status :Monitoring feature
- * No residual magnetism
- * Anodized aluminum housing
- * Dual Voltage : 12 or 24 VDC
- * Adjustable mounting bracket
- * Complete mounting hardware included
- * CE

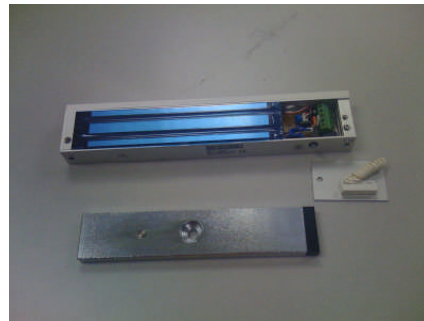

	ASC-600 SLMC	
Magnet Size	250 X 42 X 26	
Armature Size	180 X 38 X 11	
Holding Force	Up to 600 lbs	
Current Drain	480mA±10%/12Vdc	240mA±10%/24Vdc
Temperature	(-10 to 55)°C	(14 to 131)°F