

EXT Series

1200lbs Water Proof Electromagnetic Lock

Model EXT545-SLCG (Monitored Version)

DESCRIPTION

1200lbs Water Proof EM locks were designed as such to be unaffected / resisting the ingress of water under specified condition with its fully sealed electronics incased with stainless steel. This EM Lock series is fitted with cable gland. Suitable for outdoor application and harsh climate.

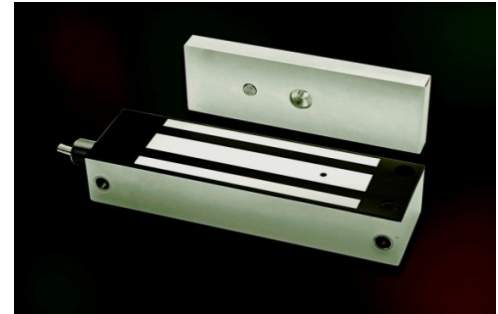

FEATURES & SPECIFICATION



Life Safety Applications



Zero Residual Magnetism



Low Energy Consumption



Cost Savings



12/24Vdc Selectable



Fully Sealed Electronics

Models	EXT545-SLCG
Features & Spec.	
Lock Status Monitoring	Reed Switch
Holding Force	Up to 1200lbs
Magnet Size	222 X 62 X 42 mm
Armature Size	185 X 61 X 16.5 mm
Current Drain	420mA±10%/12Vdc 210mA±10%/24Vdc
Operating Temperature	(-10 to 55) °C (14 to 131) °F
Housing Finishing	Stainless Steel Housing
Est. Weight	4.78kg

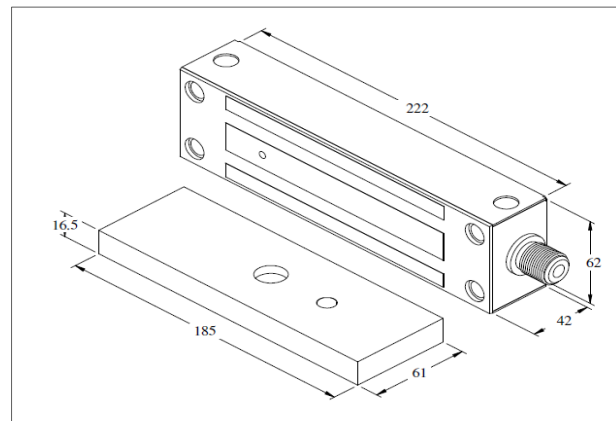

EXT Series

1200lbs Water Proof Electromagnetic Lock

STANDARD INSTALLATION DIAGRAM

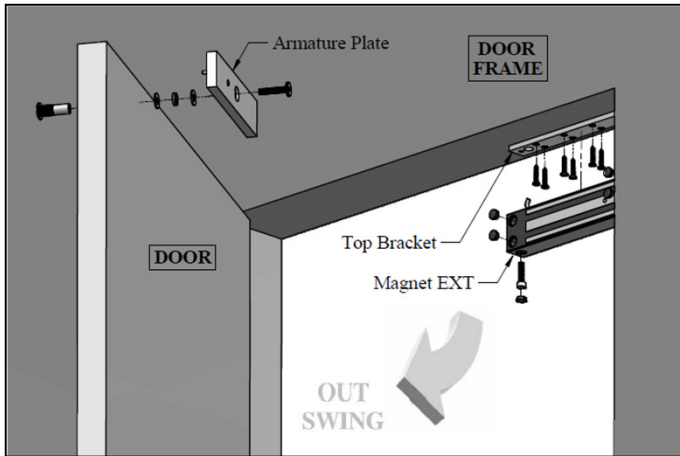

Explode View

WIRING DIAGRAM

Wiring Instruction Diagram EXT

WIRING INSTRUCTIONS

IMPORTANT!
Before the power supply is switched on,
set the wiring correctly.

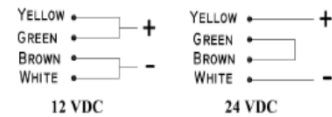

REED SENSOR CONTACT

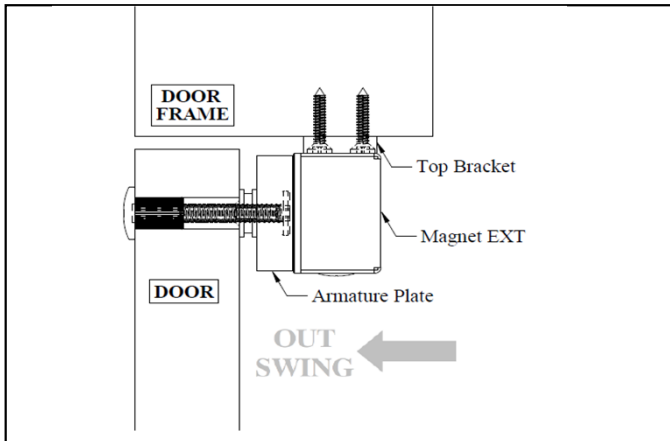

Side View

OPTIONAL - BRACKET SELECTION

LS-EXT545

Z-545