

EXT Series

1500lbs Water Proof Electromagnetic Lock

Model **EXT675-SL-A (Monitored Version)**

DESCRIPTION

1500lbs Water Proof EM locks were designed as such to be unaffected / resisting the ingress of water under specified condition with its fully sealed electronics incased with stainless steel. Suitable for outdoor application and harsh climate.

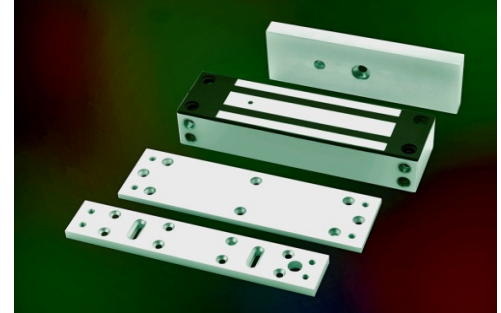

FEATURES & SPECIFICATION



Life Safety Applications



Zero Residual Magnetism



Low Energy Consumption



Cost Savings

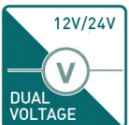

12/24Vdc Selectable



Fully Sealed Electronics

Model	EXT675-SL-A
Features & Spec.	
Lock Status Monitoring	Reed Switch
Holding Force	Up to 1500lbs
Magnet Size	222 X 62 X 42 mm
Armature Size	185 X 61 X 16.5 mm
Current Drain	480mA±10%/12Vdc 240mA±10%/24Vdc
Operating Temperature	(-10 to 55) °C (14 to 131) °F
Housing Finishing	Stainless Steel Housing
Est. Weight	5.26kg

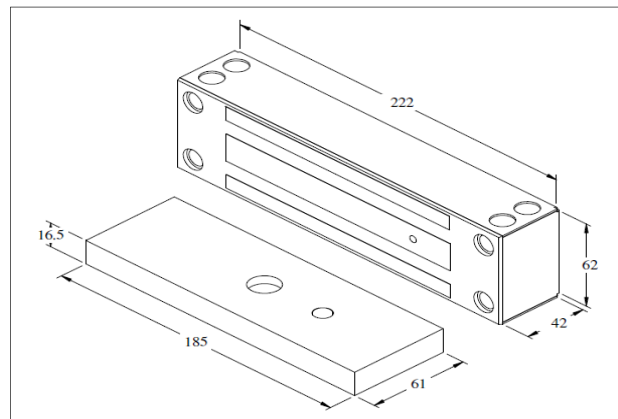

EXT Series

1500lbs Water Proof Electromagnetic Lock

STANDARD INSTALLATION DIAGRAM

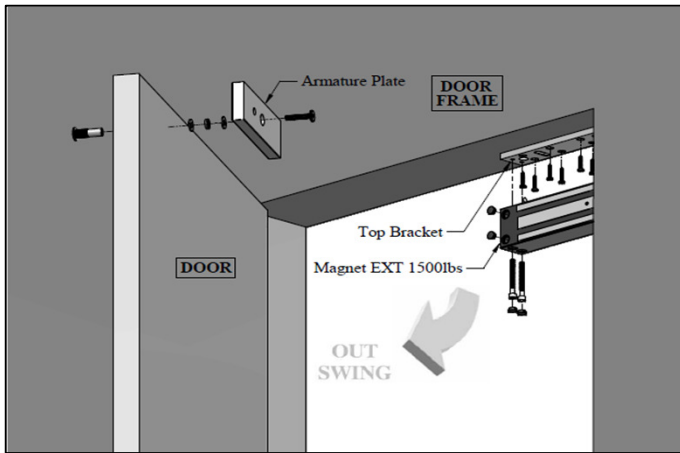

Explode View

WIRING DIAGRAM

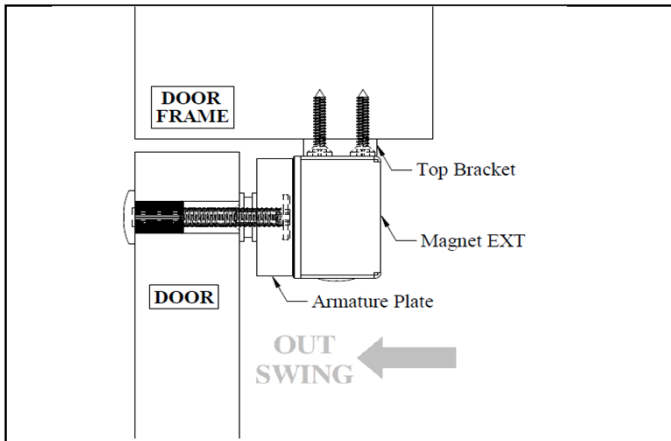
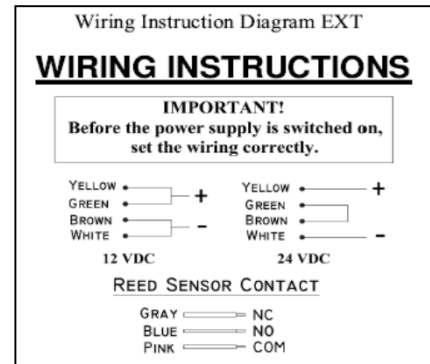

Side View

OPTIONAL - BRACKET SELECTION

LS-EXT675	Z-675
-----------	-------