

545-MC Series

1200lbs Electromagnetic Lock with Magnetic Contact

Model **UL545-SMC-A (Unmonitored Version)**
 UL545-SLMC-A (Monitored Version)

DESCRIPTION

UL545-SLMC MonAct™ series renders advance security monitoring by integrating door status monitoring function (DSMF) (providing door opened/closed signal) in addition to the standard lock status monitoring function (LSMF). MonAct™ series Monitored EM locks are inbuilt with magnetic contact were designed to meet fire and life safety applications by providing an auxiliary locking mechanism that has no moving parts to bind or wear out for trouble free operation. This will ensure inhibited release at all times where they have become extremely prevalent in applications other than fire/life safety. Suitable for higher security areas within buildings.



FEATURES & SPECIFICATION



Life Safety Applications



Zero Residual Magnetism



Low Energy Consumption



Cost Saving

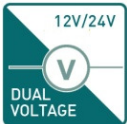

12/24V Selectable



Door Status Monitoring



Ideal for all door types

	Models	
Features & Spec.	UL545-SMC-A	UL545-SLMC-A
Lock Status Monitoring	-	✓
Door Status Monitoring	✓	
Holding Force	Up to 1200lbs	
Magnet Size	266 X 67 X 40 mm	
Armature Size	185 X 61 X 16.5 mm	
Current Drain	420mA±10%/12Vdc 210mA±10%/24Vdc	
Operating Temperature	(-10 to 55) °C (14 to 131) °F	
Housing Finishing	Anodized Aluminium	
Est. Weight	4.71kg	

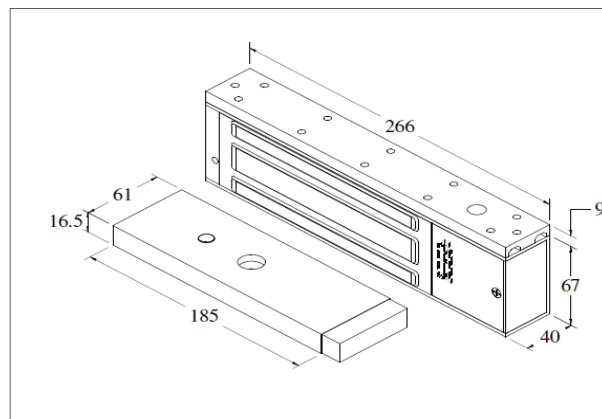

545-MC Series

1200lbs Electromagnetic Lock with Magnetic Contact

STANDARD INSTALLATION DIAGRAM

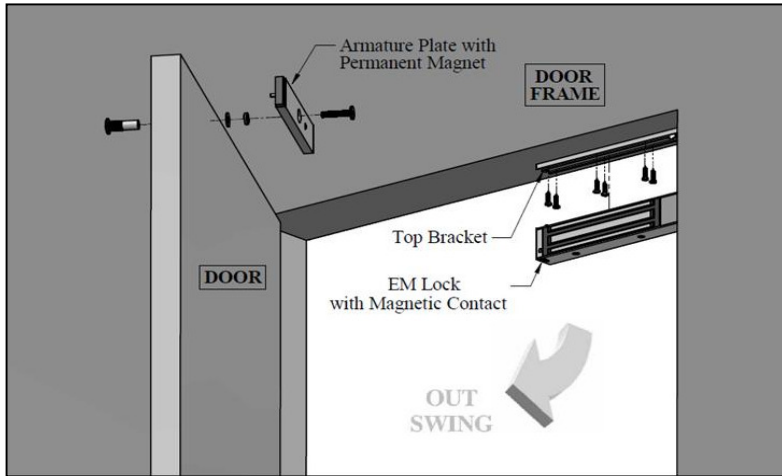

Explode View

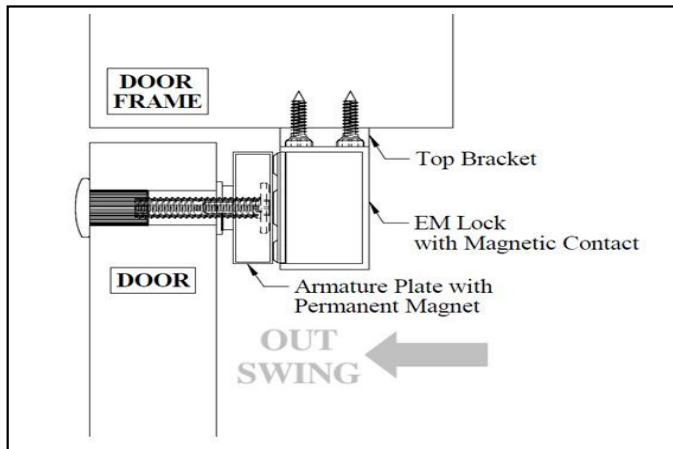

Side View

WIRING DIAGRAM

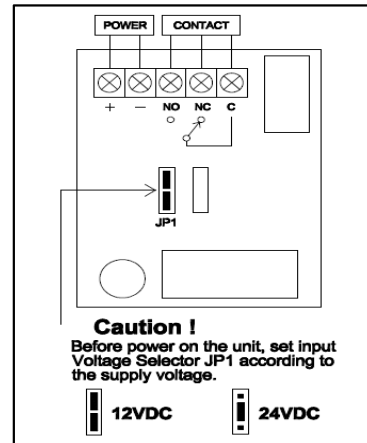

OPTIONAL - BRACKET SELECTION

LS-545	U1-545	ZL-545	ZLE-545	LSDC-545-G	ZLDC-545-G
AHM-545	AB-545				